

Coaxial Gas Discharge Tube (GDT)

Part Number: **CA-200 / CA-200(tin)**



Features:

- Protects Against Lightning, Surges, and Over Voltages
- Low Capacitance
- Bi-Directional
- High Current and Multiple Strike Capability
- Non-Radioactive and Maintenance Free
- ISO 9001 & ISO 14001 Certified
- RoHS Compliant
- UL Recognized (497B File E140906)
- Compact Size To Fit Inside Coaxial Cable and Connectors
- Available in Nickel or Tin Plating
(CA-200 - Nickel plating ; CA-200(tin) - Tin plating)



100% Lead-Free (RoHS Compliant)

Electrical Characteristics	
DC Breakdown Voltage (≤ 100 V/sec)	200V \pm 25%
Impulse Breakdown Voltage (1 kV/ μ sec)	≤ 700 V
Insulation Resistance (at 100VDC)	$\geq 10,000$ M Ω (between central line electrode and outer "shielding" electrode)
Capacitance (at 1MHz)	≤ 1.5 pF
Technology Type	Gas Discharge Tube
Impulse Life (with 10/1000 μ sec impulse)	100A (300 times)
Impulse Discharge Current (with 8/20 μ sec impulse)	5kA (10 times) 10kA (1 time)
After Life Performance (Specs after exceeding Impulse Life or Impulse Discharge Current conditions)	
DC Breakdown Voltage (≤ 100 V/sec)	200V \pm 50%
Impulse Breakdown Voltage (1 kV/ μ sec)	≤ 900 V
Insulation Resistance (at 100VDC)	≥ 100 M Ω (between central line electrode and outer "shielding" electrode)
Mechanical Characteristics	
Connector Type	2-Electrode [Central Line (end terminals shorted) & Outer "Shielding"]
Mounting Method	Inside Coaxial Cable or Connector
Grounding	Outer "Shielding" Electrode
Material	CA-200: Nickel Plated, CA-200(tin): Tin Plated
Weight	1.4g (0.05oz)
Environmental Characteristics	
Operating Temperature Range	-40°C to +90°C (-40°F to 194°F)
Relative Humidity	$\leq 90\%$ non-condensing

Applications:

- Transient Voltage Surge Suppression (TVSS)
- Routers and Access Points
- Wireless Communication Systems
- Tower Top and Tower Base Electronics
- Narrow and Broadband
- Modems/Cable Modems
- Broadband/CATV/Coaxial Protectors

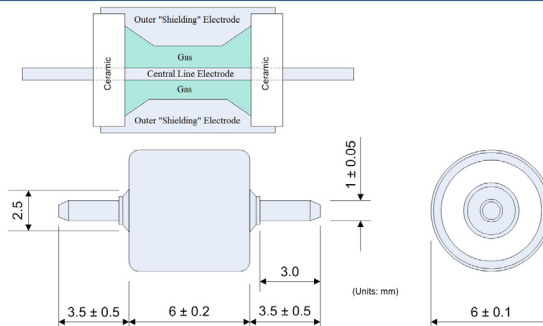

SANKOSHA

SANKOSHA