

# Three Electrode Gas Tube Surge Arrester

Part Number: 3J-4J1

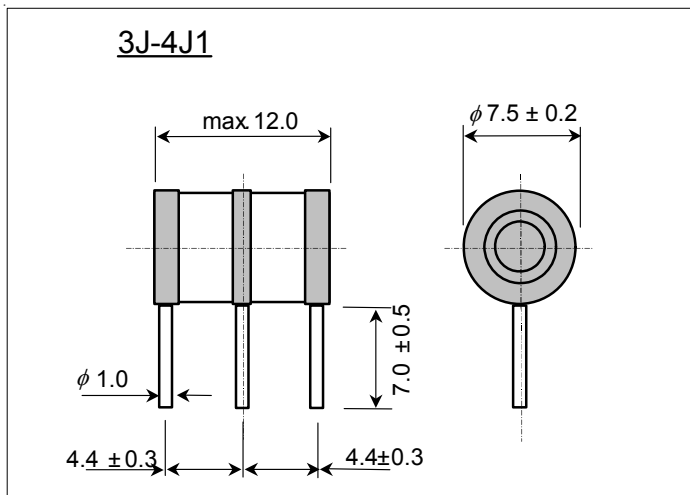

## Applications:

Transient Voltage Surge Suppression  
 Telephone Network Interfaces  
 Modems/Cable Modems  
 xDSL Modems and Peripherals  
 Building Entry/Outside Plant

## Features:

UL 497B Recognized  
 UL File E140906  
 Non-Radioactive  
 100% Lead-Free (RoHS Compliant)  
 Durable Construction  
 Low Capacitance  
 Proven Performance  
 ISO 9001 Certified

## Marking

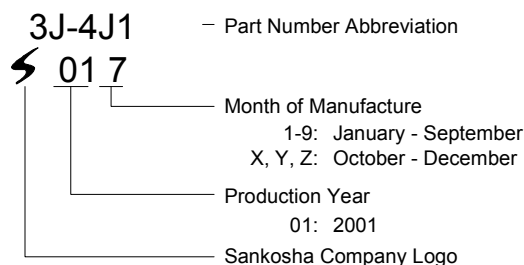

## Electrical Characteristics

1.	DC Breakdown Voltage	100 V/sec	250V ± 20%	(L1-E) (L2-E)		
2.	Impulse Breakdown Voltage	100 V/μsec	< 500 V	(L1-E) (L2-E)		
		1 kV/μsec	< 650 V	(L1-E) (L2-E)		
3.	Insulation Resistance	DC 100 V	> 10,000 M-ohm			
4.	Capacitance	1 MHz	< 3.0 pF			
5.	DC Holdover Voltage	See Note	< 135V	Note: ITU-T K.12 or IEEE C62.31-1987 Test Circuit		
6.	Impulse Life	10/1000 μsec	400 A	300 Times	(L1+L2-E)	
7.	Impulse Discharge Current	8/20 μsec	20 kA	1 Time	(L1+L2-E)	
		8/20 μsec	10 kA	Each Polarity 5 Times	(L1+L2-E)	
8.	AC Discharge Current	50 Hz	130 A	9 cycles	1 Time	(L1+L2-E)
		50 Hz	10 A	One Second	10 Times	(L1+L2-E)

## After Life Tests

9.	DC Breakdown Voltage	100 V/sec	250V ± 50%			
10.	Impulse Breakdown Voltage	100 V/μsec	< 900 V			
11.	Insulation Resistance	DC 100 V	> 1 M-ohm			

SANKOSHA

SANKOSHA