

# Two Electrode Surface Mount Gas Tube Arrestor

Part Number: **SD4-145**



**Features:**



- 4.4 x 3.5 mm footprint
- Ideal for surface mount applications
- Non-Radioactive
- 100% Lead-Free (RoHS Complaint)
- Low Capacitance
- Proven Performance
- ISO 9001 Certified

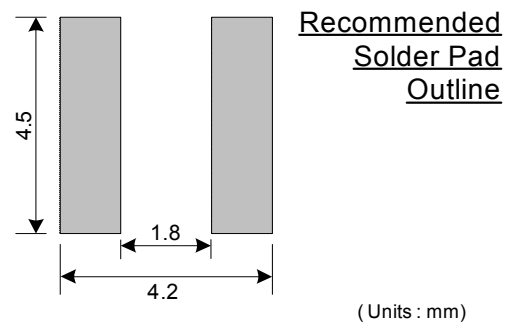
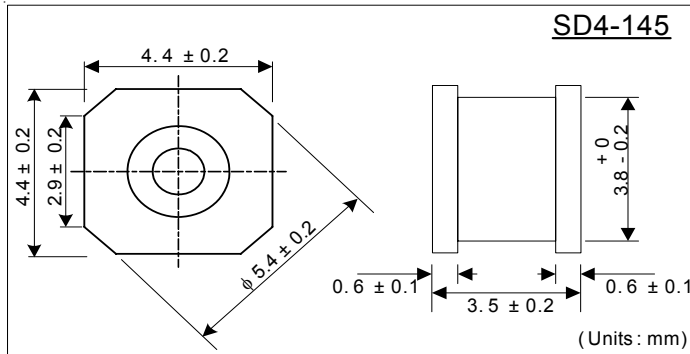

**Applications:**

- Transient Voltage Surge Suppression
- Cable Telephony Products
- Modems/Cable Modems
- Broadband/CATV/Coaxial Protectors
- xDSL Modems and Peripherals
- Building Entry/Outside Plant

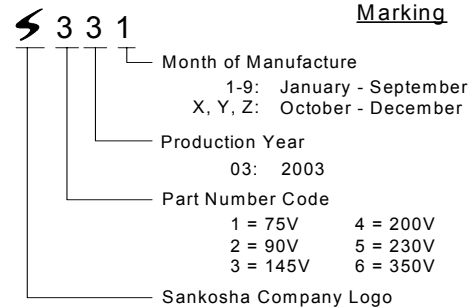

**Electrical Characteristics**

1.	DC Breakdown Voltage	100 V/sec	145V ± 20%		
2.	Impulse Breakdown Voltage	1 kV/μsec	< 600V		
3.	Insulation Resistance	DC 50V	> 10,000 M-ohm		
4.	Capacitance	1 MHz	< 0.5 pF		
5.	DC Holdover Voltage	See Note	< 80V	Note: Measured in accordance with ITU-T K.12.	
6.	Impulse Life	8/20 μsec	100A	> 1000 times	
7.	Impulse Discharge Current	8/20 μsec	2.5 kA	1 Time	
8.	AC Discharge Current	50 Hz	One Second	5 A	1 Time

**After Life Tests**

9.	DC Breakdown Voltage	100 V/sec	145 ± 30%		
10.	Impulse Breakdown Voltage	1 kV/μsec	< 700V		
11.	Insulation Resistance	DC 50V	> 100 M-ohm		

SANKOSHA

SANKOSHA